

IMV VIBRATION TEST SYSTEMS

i series

Air cooled Vibration Test Systems

i260 / SA7AM

EM2601A

Vibration tests have diversified and specifications have become increasingly strict. i-series offer a user-friendly lineup with enhanced performance and durability.

[Expanded maximum test range]

Max. velocity of Sine force: 2.4 m/s • Max. velocity of Shock force 4.6 m/s • Max. displacement: 100mmp-p

[Patented upper (armature) support system PS Guide] Parallel Slope Guide is standard.

[Low noise] Optimised design of the air intake based on fluid dynamics has reduced the air-intake noise.

[All models can be directly coupled to a climatic chamber.]



① High durability with PS guide

PS guide (parallel slope guide) is an upper support system conforming to continued vibration testing at high velocity.

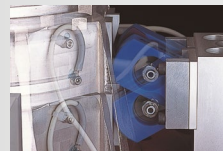

■ PS guide system

② Improvement of Testing Environment

With the operation of Intelligence Shaker Management (ISM), EM range can reduce power consumption and CO2 emissions automatically.

eco-shaker

③ User first principle

Compatible with K2 vibration controller. Intuitive interface leads The operator with user-friendly guidance.



IMV VIBRATION TEST SYSTEMS

i series

Air cooled Vibration Test Systems

i260 / SA7AM EM2601A



System Specifications			
System Model		i260/SA7AM	EM2601A
Frequency Range (Hz)		0-2600*3	
Rated Force	Sine (kN)	54	
	Random (kN rms)*1	54	
	Shock (kN)	108	
Maximum Acc.	Sine (m/s ²)	1000	
	Random (m/s ² rms)	700	
	Shock (m/s ²)	2000	
Maximum Vel.	Sine (m/s)	2.2	
	Shock (m/s peak)	2.2	2.2(3.5)*4
Maximum Disp.	Sine (mmp-p)	51	
	Maximum Travel (mmp-p)	64	

Vibration Generator (i260)	
Armature Mass (kg)	54
Armature Diameter (φ mm)	446
Armature Resonance (Hz)	1800
Allowance Eccentric Moment (N.m)	1550
Maximum Payload (kg)	1000
Mass (kg)	3500

- *1) Random force ratings are specified in accordance with ISO5344 conditions.
- *2) Power supply: 3-phase 380/400/415/440 V, 50/60 Hz. A transformer is required for other supply voltages.
- *3) Above 2000 Hz, the force rolls-off at a rate of -12 dB/oct.
- *4) Maximum velocity 4.6 m/s. High velocity restricts maximum Shock force. Please contact IMV or your local distributor with specific test requirements.
- * The specification shows the maximum system performance. For long-duration tests, de-rating by up to 70 % must be applied. Continuous use at maximum levels may cause failure.
- * In the case of Random vibration test, please set the test definition of the peak value of acceleration waveform to be operated less than the maximum acceleration of Shock.
- * Frequency range values vary according to sensor and vibration controller.

Cooling Blower		
Model	VAPE 710/N2	
Mass (kg)	250	
Environmental Data		
Power Requirement (kVA)*2	83	
Input Voltage Supply (3φ, V)	380/400/415/440	
Compressed Air Supply (Mpa)	0.7	
Working Ambient	Temperature (°C)	0 - 40
	Humidity (%RH)	0 - 85

Power Amplifier		
System Model	SA7AM-i60	SA7AM-i60EM
Maximum Output [kVA]	64	
Mass [kg]	1400	

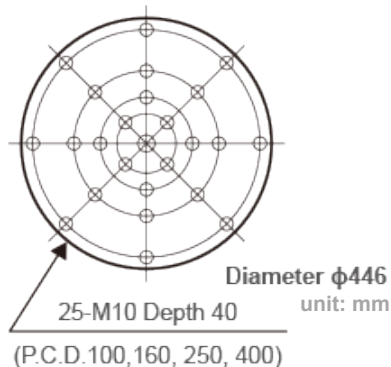

i260

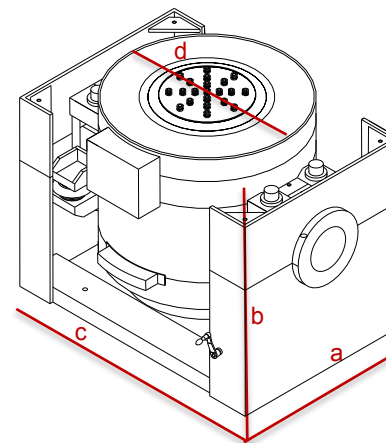

Shaker

Model: i260

- a: W 1527 mm
- b: H 1198 mm
- c: D 1100 mm
- d: 920 φmm

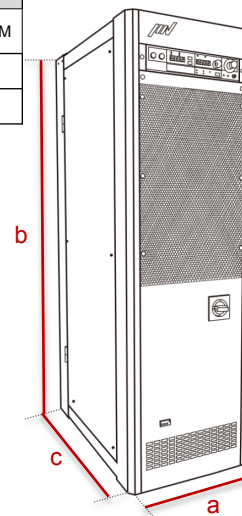

Amplifier

Model: SA7AM-i60
Model: SA7AM-i60EM

- a: W 1160 mm
- b: H 1950 mm
- c: D 850 mm

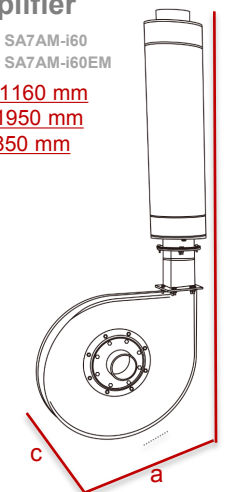

Blower

Model: VAPE 710/N2

- a: W 1160 mm
- b: H 2405 mm
- c: D 787 mm