

IMV VIBRATION TEST SYSTEMS K series

Water cooled Vibration Test Systems

K100LS / SA16HAM EMK1255A



K series vibration test system is ideal for testing of large sized specimen with high acceleration test requirements, in the field of electronic assemblies, automotive parts, aviation, avionics parts satellite. K series is designed to meet international test standards including IEC, ISO and JIS.

IMV's patented upper (armature) support system; Parallel Slope Guide has improved the durability of the system extending the lifetime of the upper guidance system, with a lifetime of up to several times greater than the other standard shaker. Extended displacement available up to 100mm (4 inch) with K series.



① High Excitation Force and Long Stroke

Force rating up to 200 kN, wide frequency range up to 3,000. To allow long stroke testing, maximum displacement 100 mm (4 inch) is available with K125LS shaker.



■ PSG guide system

② Easy maintenance

- All connections of electricity and water are in the upper part of the armature.
- It is easy to inspect and change the armature



③ Improvement of Testing Environment

No exhaust noise of the cooling blower. Further, with the operation of intelligence Shaker Management (ISM), EM range can reduce power consumption and CO2 emissions automatically.

eco-shaker



System Specifications		
System Model		K100LS/SA16HAM  EMK1255A
Frequency Range (Hz)		0-2000
Rated Force	Sine (kN)	100
	Random (kN rms) *1	100
	Shock (kN)	200
Maximum Acc.	Sine (m/s ²)	1000
	Random (m/s ² rms)	700
	Shock (m/s ²)	2000
Maximum Vel.	Sine (m/s) *3	2.0
	Shock (m/s peak)	2.0
Maximum Disp.	Sine (mmp-p)	100
	Maximum Travel (mmp-p)	132

Vibration Generator (K125LS)	
Armature Mass (kg)	100
Armature Diameter (φ mm)	560
Armature Resonance (Hz)	1700
Allowance Eccentric Moment (N·m)	2450
Maximum Payload (kg)	2000
Mass (kg)	8000

*1) Random force ratings are specified in accordance with ISO5344 conditions.
 *2) Power supply: 3-phase 380/400/415/440 V, 50/60 Hz. A transformer is required for other supply voltages.
 *3) If the tests (Sweep or Spot) include high velocity, the maximum velocity value should be reduced to 1.4 m/s.
 * The specification shows the maximum system performance.
 For long-duration tests, de-rating by up to 70 % must be applied.
 Continuous use at maximum levels may cause failure.
 * In the case of Random vibration test, please set the test definition of the peak value of acceleration waveform to be operated less than the maximum acceleration of Shock.
 * Frequency range values vary according to sensor and vibration controller.

Heat Exchanger		
System Model		VE-HE-150-SA
Mass (kg)		400
Environmental Data		
Power Requirement (kVA) *2		170
Input Voltage Supply (3 φ, V)		380/400/415/440
Compressed Air Supply (Mpa)		0.7
Facility Cooling Water Flow (l/min)		390 at Δt = 5°C 151 at Δt = 12°C
Working Ambient Condition	Temperature (°C)	0 - 40
	Humidity(%RH)	0 - 85

Power Amplifier		
System Model		SA16HAM-K125LS  EM16HAM-K125LS
Maximum Output [kVA]	124	124
Mass [kg]	2600	2650

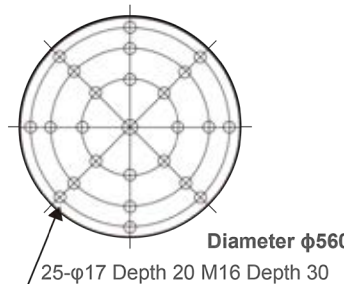

(P.C.D.250, 400, 500) unit: mm
K125LS

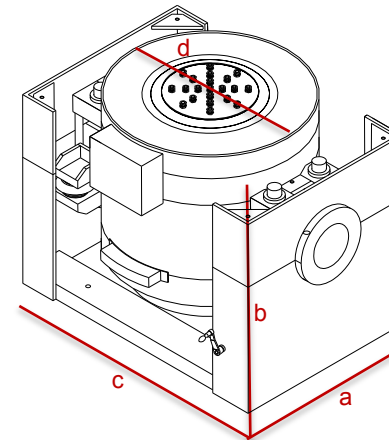

Shaker
Model: K125LS

a: W 1990 mm
b: H 1546 mm
c: D 1370 mm
d: 1100 φmm

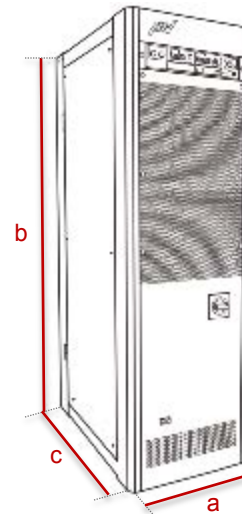

Amplifier
Model: SA20HAM-K125LS
Model: EM20HAM-K125LS

a: W 1740 mm
b: H 1950 mm
c: D 850 mm

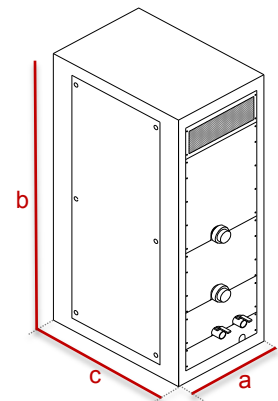

Heat Exchanger
Model: VE-HE-150-SA

a: W 580 mm
b: H 1700 mm
c: D 850 mm