

IMV VIBRATION TEST SYSTEMS

K series

Water cooled Vibration Test Systems

K160 / SA20HAM EMK2001A



K series vibration test system is ideal for testing of large sized specimen with high acceleration test requirements, in the field of electronic assemblies, automotive parts, aviation, avionics parts satellite. K series is designed to meet international test standards including IEC, ISO and JIS.

IMV's patented upper (armature) support system; Parallel Slope Guide has improved the durability of the system extending the lifetime of the upper guidance system, with a lifetime of up to several times greater than the other standard shaker. Extended displacement available up to 100 mm (4 inch) with K series.



① High Excitation Force and Long Stroke

Force rating up to 200 kN, wide frequency range up to 3,000. To allow long stroke testing, maximum displacement 100 mm (4 inch) is available with K125LS shaker.



■ PSG guide system

② Easy maintenance

- All connections of electricity and water are in the upper part of the armature.
- It is easy to inspect and change the armature



③ Improvement of Testing Environment

No exhaust noise of the cooling blower. Further, with the operation of intelligence Shaker Management (ISM), EM range can reduce power consumption and CO2 emissions automatically.

eco-shaker



System Specifications		
System Model	K160/SA20HAM	EMK2001A
Frequency Range (Hz)	0-2000	
Rated Force	Sine (kN)	160
	Random (kN rms) *5	160
	Shock (kN)	320
Maximum Acc.	Sine (m/s ²)	800
	Random (m/s ² rms)	560
	Shock (m/s ²)	1600
Maximum Vel.	Sine (m/s) *3	2.0
	Shock (m/s peak)	2.4
Maximum Disp.	Sine (mmp-p)	76.2
	Maximum Travel (mmp-p)	86

Vibration Generator (K200)	
Armature Mass (kg)	200
Armature Diameter (φ mm)	650
Armature Resonance (Hz)	1600
Allowance Eccentric Moment (N·m)	4900
Maximum Payload (kg)	2000
Mass (kg)	16000

Heat Exchanger		
System Model	VE-HE-150-SA	
Mass (kg)	600	
Environmental Data		
Power Requirement (kVA) *2	270	
Input Voltage Supply (3 φ, V)	380/400/415/440	
Compressed Air Supply (Mpa)	0.7	
Facility Cooling Water Flow (l/min)	650 at Δt = 5°C 229 at Δt = 12°C	
Working Ambient Condition	Temperature (°C)	0 - 40
	Humidity (%RH)	0 - 85

Power Amplifier		
System Model	SA20HAM-K200	EM20HAM-K200
Maximum Output [kVA]	256	256
Mass [kg]	4850	4850

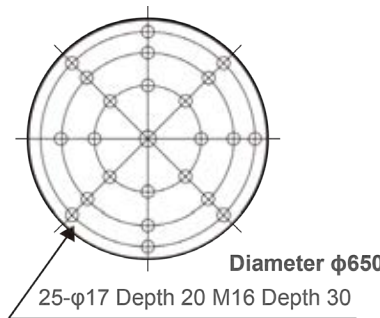

(P.C.D.203.2, 406.4, 558.8) unit: mm

K200

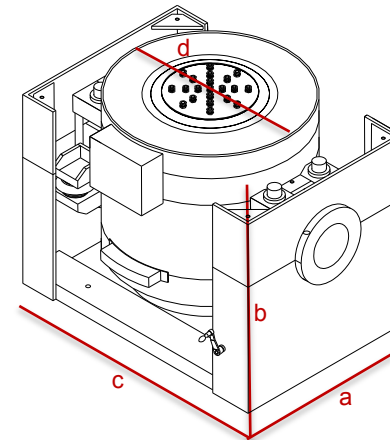

Shaker

Model: K200

- a: W 2465 mm
- b: H 1908 mm
- c: D 1740 mm
- d: 1260 φmm

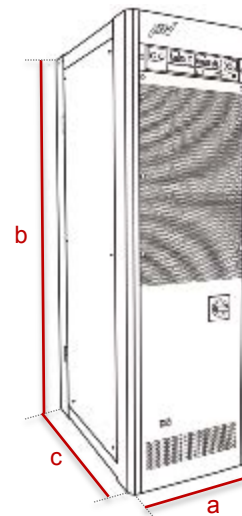

Amplifier

Model: SA20HAM-K200
Model: EM20HAM-K200

- a: W 2900 mm
- b: H 1950 mm
- c: D 850 mm

Heat Exchanger

Model: VE-HE-200-SA

- a: W 1050 mm
- b: H 1900 mm
- c: D 800 mm

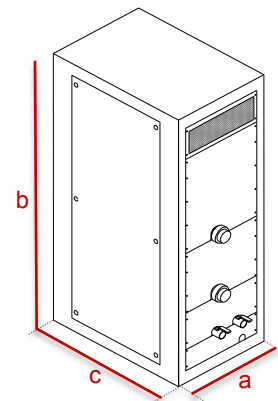

*1) Random force ratings are specified in accordance with ISO5344 conditions.
*2) Power supply: 3-phase 380/400/415/440 V, 50/60 Hz. A transformer is required for other supply voltages.
*3) If the tests (Sweep or Spot) include high velocity, the maximum velocity value should be reduced to 1.4 m/s.
* The specification shows the maximum system performance.
For long-duration tests, de-rating by up to 70 % must be applied.
Continuous use at maximum levels may cause failure.
* In the case of Random vibration test, please set the test definition of the peak value of acceleration waveform to be operated less than the maximum acceleration of Shock.
* Frequency range values vary according to sensor and vibration controller.